



Peddinghaus Anlagen & Maschinen GmbH



Peddimaster

Dispositivo de cambio rápido de punzonado

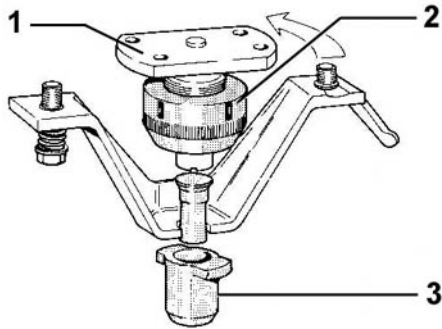

Peddimaster
100/160
110/170
1100/1700

Peddimaster
800/1100

Peddimaster
28/40 • 40/60
60/80 • 60/100
80/110

Serie verde



No. 2
No. 5

hasta Ø 32 mm

Serie verde



No. 2
No. 5

hasta Ø 32 mm

Serie roja



No. 1
No. 4

hasta Ø 27 mm

	Descripción	No. ref.	No. ref.	No. ref.																
	1 portapunzón	44081 199 990	40615 5 6001 00	44001 199 990																
		<table border="1"> <tr><td>A</td><td>B</td><td>C</td></tr> <tr><td>100</td><td>37</td><td>47</td></tr> </table>	A	B	C	100	37	47	<table border="1"> <tr><td>A</td><td>B</td><td>C</td></tr> <tr><td>62</td><td>37</td><td>22</td></tr> </table>	A	B	C	62	37	22	<table border="1"> <tr><td>A</td><td>B</td><td>C</td></tr> <tr><td>71</td><td>32</td><td>28</td></tr> </table>	A	B	C	71
A	B	C																		
100	37	47																		
A	B	C																		
62	37	22																		
A	B	C																		
71	32	28																		
	2 tuerca tensora rápida	44081 198 991	44081 198 991	44001 198 991																
		<table border="1"> <tr><td>A</td><td>B</td><td>C</td></tr> <tr><td>45</td><td>85</td><td>52,5</td></tr> </table>	A	B	C	45	85	52,5	<table border="1"> <tr><td>A</td><td>B</td><td>C</td></tr> <tr><td>45</td><td>85</td><td>52,5</td></tr> </table>	A	B	C	45	85	52,5	<table border="1"> <tr><td>A</td><td>B</td><td>C</td></tr> <tr><td>38</td><td>70</td><td>45,5</td></tr> </table>	A	B	C	38
A	B	C																		
45	85	52,5																		
A	B	C																		
45	85	52,5																		
A	B	C																		
38	70	45,5																		
	3 tensor rápido	44081 198 992	42030 6 2191 02	44001 198 992																
		<table border="1"> <tr><td>A</td><td>B</td><td>C</td></tr> <tr><td>60</td><td>32,2</td><td>52</td></tr> </table>	A	B	C	60	32,2	52	<table border="1"> <tr><td>A</td><td>B</td><td>C</td></tr> <tr><td>35</td><td>32,2</td><td>52</td></tr> </table>	A	B	C	35	32,2	52	<table border="1"> <tr><td>A</td><td>B</td><td>C</td></tr> <tr><td>44</td><td>27,1</td><td>45</td></tr> </table>	A	B	C	44
A	B	C																		
60	32,2	52																		
A	B	C																		
35	32,2	52																		
A	B	C																		
44	27,1	45																		

	tensor rápido especial	 No. 5	para punzón para cerradura 44081 6 2928 03	
	tensor rápido especial	 No. 4 de gran tamaño	 Ø 28 – 29 – 30 mm	44001 6 3523 01
			 □ 20 – 21 mm	65004 8087 01
			 L = 28 – 30 mm	44001 6 3503 03